

Family Trees, Genograms and Ecomap Guidance

Updated October 2018 Review October 2021

Purpose

A family tree or genogram helps to provide a readily accessible picture of current family relationships over three or more generations. It provides information about key family members and shows how the child/children sit within the complex dynamics of their families. It is a tool that support rapport building and assessment and should be done with all families that we work with. It can help social workers:

- Know who is in the family
- Explore family dynamics and relationships
- Know what has happened to the family
- Illuminate the way in which past and present separations, losses, transitions and traumas have been part of family members' life experiences
- See intergenerational patterns of:
 - Parenting
 - Substance misuse
 - Mental health
 - Domestic abuse
- Understand where the family turns for support
- Understand how the family 'fit' in relation to larger society:
 - Neighbours
 - Other organisations
 - Their community

Principals

- Do it with the family and at their pace
- Plan your approach well, think about using different tools to capture the information and the types of questions you will use
- Discuss with the family who will have copies and what you will be doing with your copy
- Try doing your own family first, that way you will understand how it works and what it can feel like

Methods and Approaches

- Use large sheets of paper – flip chart paper is best
- Take a range of colour pen

Decide who to start with – an individual or the whole family

- Consider different approaches to gather the information, depending on the age of the child and how the family best communicate, such as:
 - Different types of pictures
 - Modelling clay
 - Dolls houses
- Consider the impact of putting on paper, painful information about deaths and separations and structure your visit appropriately

Genogram/Family Trees

Always:

- Aim to be consistent in your approach
- Ensure dates of birth are put inside the symbols (rather than ages as these change over time)
- Put names under the symbol
- Leave yourself plenty of space
- Start at the bottom with the children
- Try and work left to right with oldest on the left
- Use the symbols to denote the relationships between the adults
- Include dates of separation when known and ensure it is clear which parent the children remain with
- Keep updated and reviewed

Optional

- Use the emotional relationship symbols to record intergenerational issues. Put a key on the paper if you do this
- Consider whether to include pets
- Show who is living in which households by putting a dotted line around the households

Symbols



Female adult or child



Male, adult or child



Pregnancy



Miscarriage

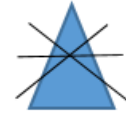

Abortion



Pet



Death, for example death of a male would look like this

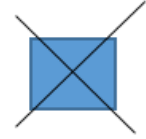

————— Ensuring adult relationship/marriage or blood

----- Adult relationship / non-marital couple relationship

04/02/2010

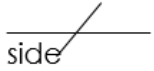

Separation of a married couple, children remain with the parent on one of the diagonal line

04/04/2012

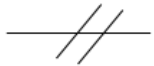

Divorce of a married couple in April

04/04/2012

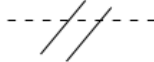

Separation of a couple

An example of a simple family tree

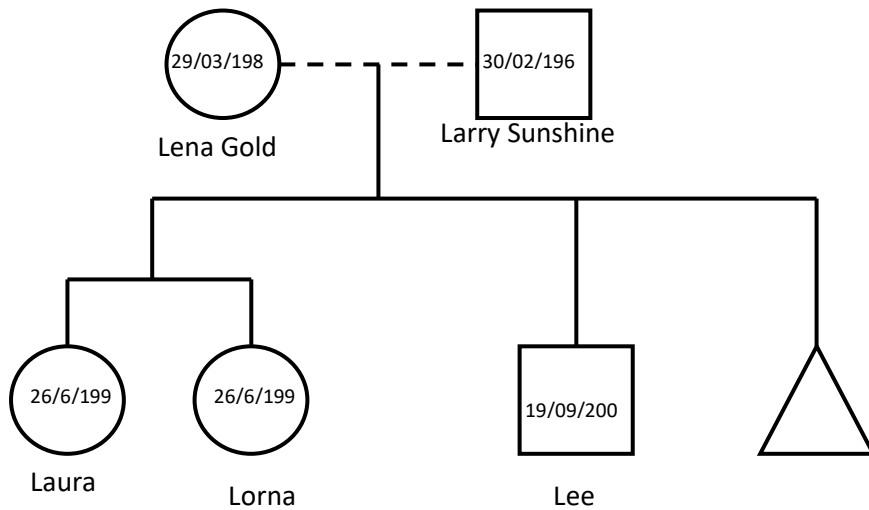

This tells us that Lena Gold had her first children (twin girls) with Larry when she was 16. She continues to live with him, as co-habitants, and has had another child; she is now pregnant.

Additional symbols

Assisted Conception

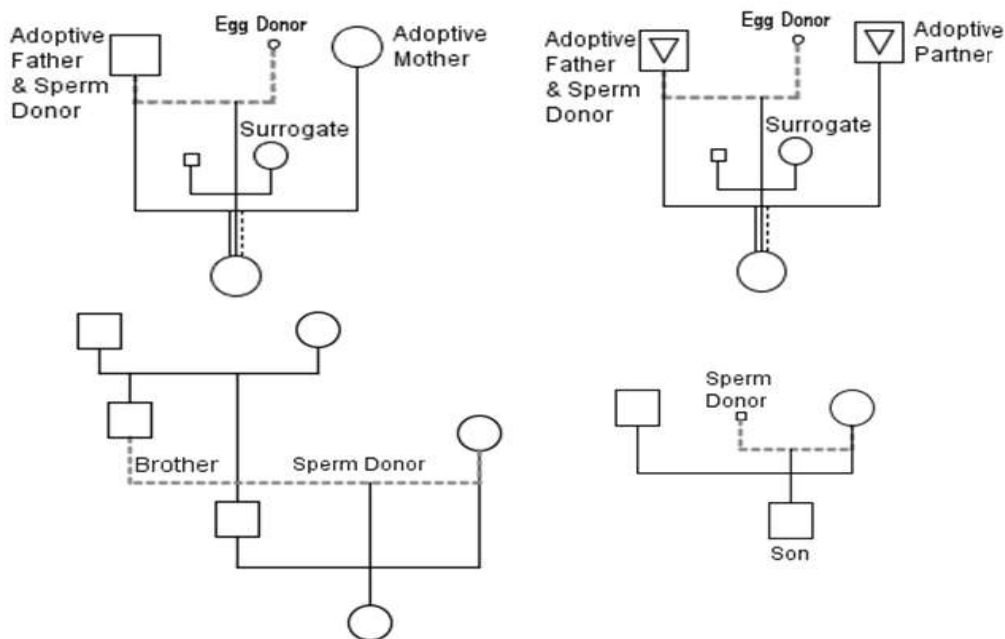

Genogram Symbols

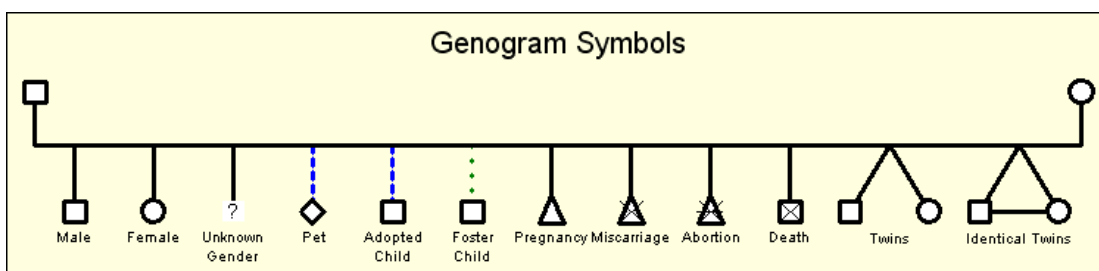

Gay / Lesbian

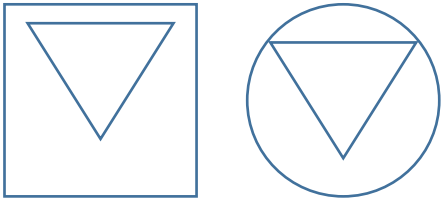

Transgender People

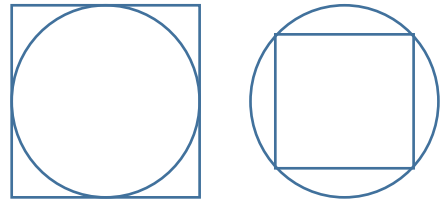

Trans woman Trans man

An example of a more complex family tree

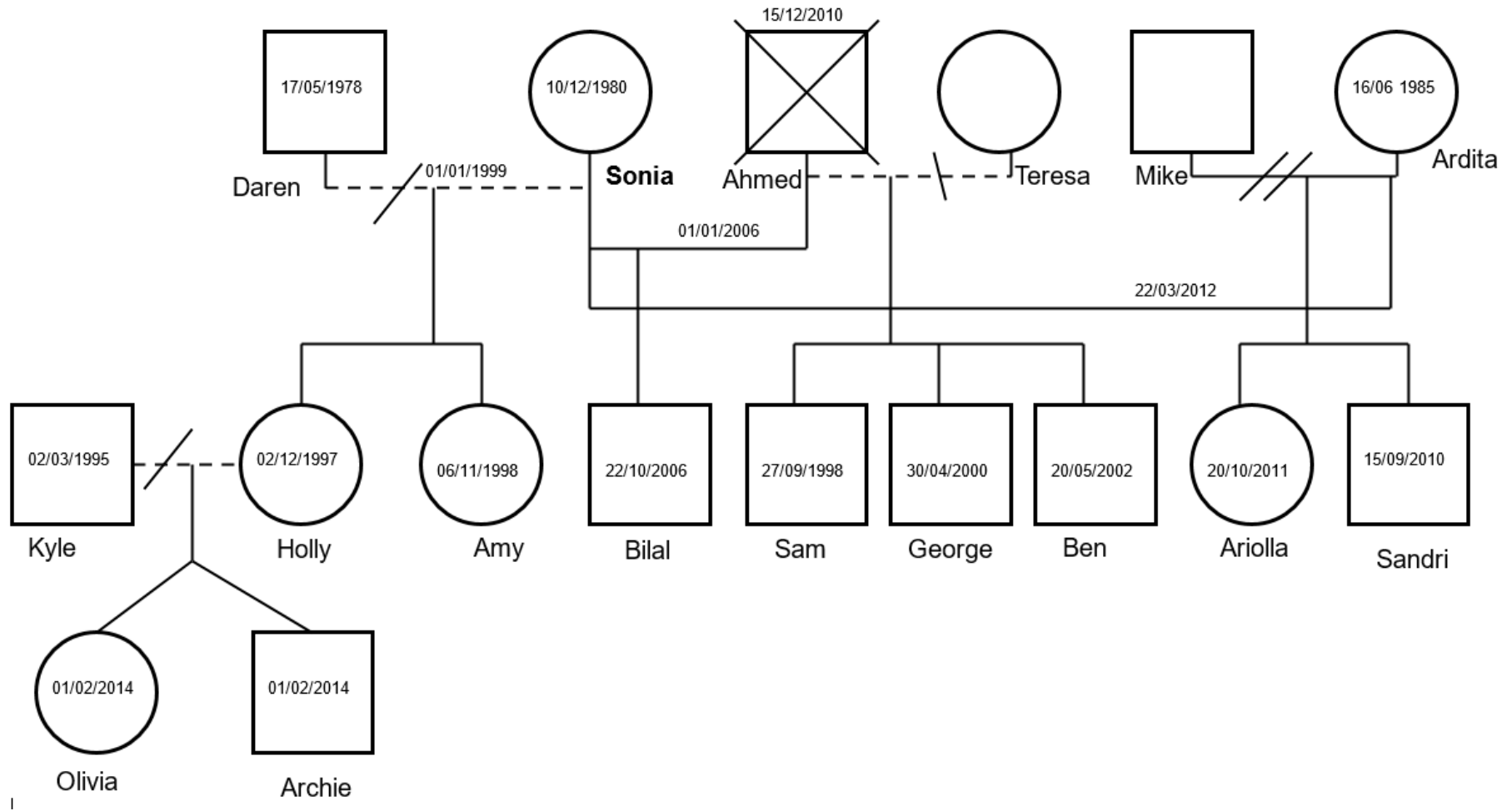

This tells us that Sonia was in a relationship with Daren and they had two girls, Holly and Amy. This ended in 1999. Sonia then met and married Ahmed who had his three boys from his previous relationship with Teresa with him. Sonia and Ahmed had Bilal in 2006 and Ahmed died in 2010. Sonia then met Ardita who had her two children Ariona and Sandri living with her. Ardita and Sonia had their civil partnership in 2012. In 2013 Sonia's eldest daughter Holly had twins with her partner Kyle. This relationship has ended and Holly, Olivia, Archie, Amy, Bilal, Sam, George, Ben, Ariolla and Sandri all live with Sonia and Ardita.

Family tree showing emotional relationships and who is living in Sonia's household
 The dotted line shows who live in the same household together. The zigzag red line shows violence and the blue dotted line shows neglect.

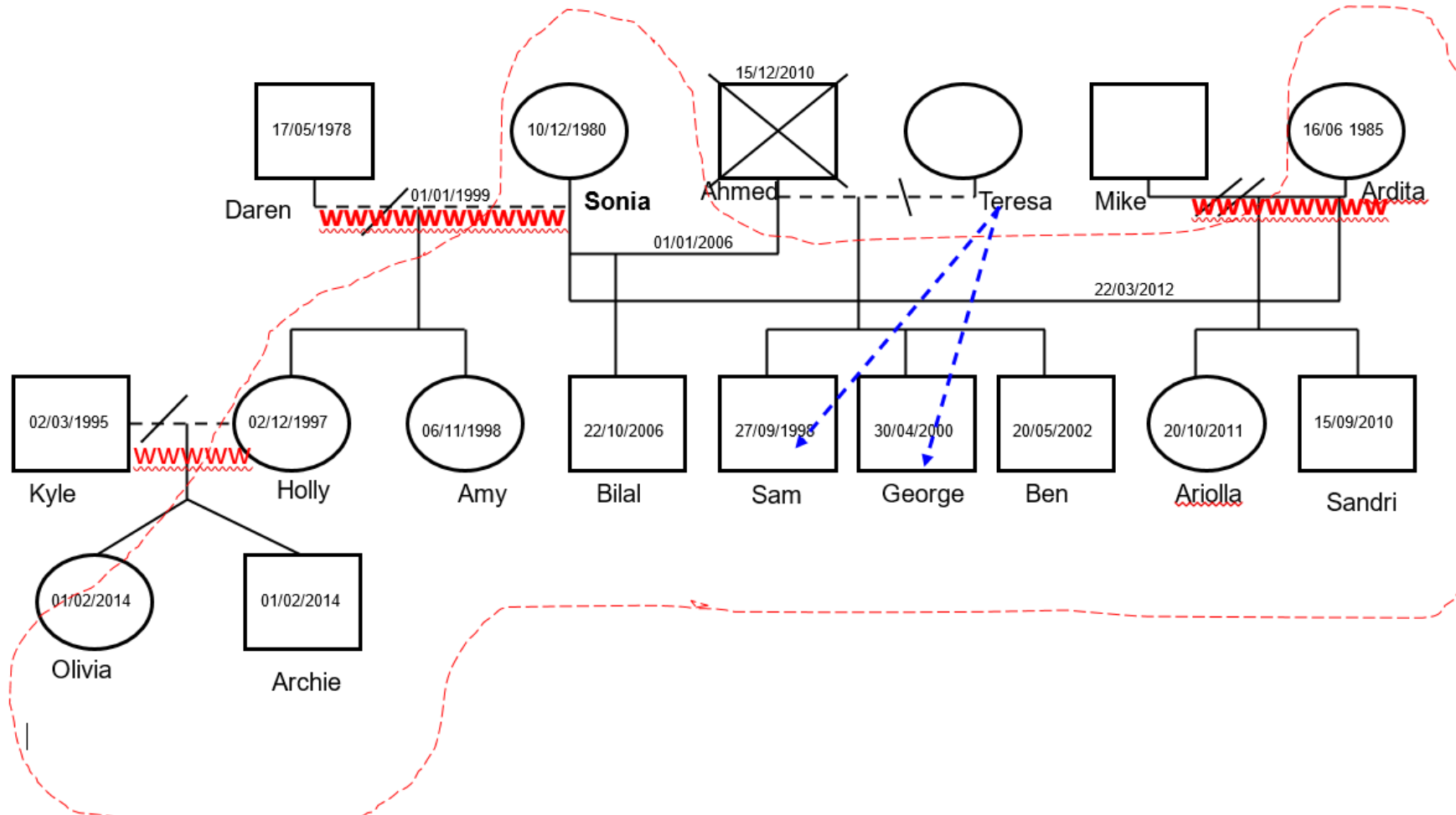

Eco-maps

An ecomap is a picture that maps the connection the family has with their community, the quality of those connections and how much energy those connections use up.

You can do a whole family ecomap which captures the inner workings of the family – the quality of their internal relationships as well as their external ones.

You can do individual ones with children and different members of the family to capture a greater understanding of the whole family dynamic.







There are a variety of approaches to making an ecomap. The quality of your relationship with the child/young person/family and your ability to engage them in the task will have the most significance. We have given you three examples of different approaches to ecomaps, all using the same example of a child, living with their mum and step dad who has had extensive dental work and is being bullied at school.

In the first example, the child puts themselves in the middle of the paper – it can also be the middle of an island – the galaxy or house – and they then show how they feel towards different people by how they position them on the page. In the second example, the child is in the middle, but we use different types of lines to show the nature of the relationship. Sometimes a relationship will vary, and the child can use more than one line to show how this is (it is important to use a key at the side of the page). In the third example we have included a small family tree in the middle and this can show the different relationships within the family and how different family members can have different relationships with school, neighbours etc.

You will need:

- Pens
- Paper
- Circles to draw around
- Blank outlines of islands or favourite object of the child or young person

Guide to the symbols

	<p>A strong connection</p>
	<p>A tenuous connection</p>
	<p>A stressful connection</p>
	<p>A flow of energy away from female in the household</p>
	<p>A flow of energy towards the female in the household</p>
	<p>A flow of energy towards and away from the same source</p>

Example 1

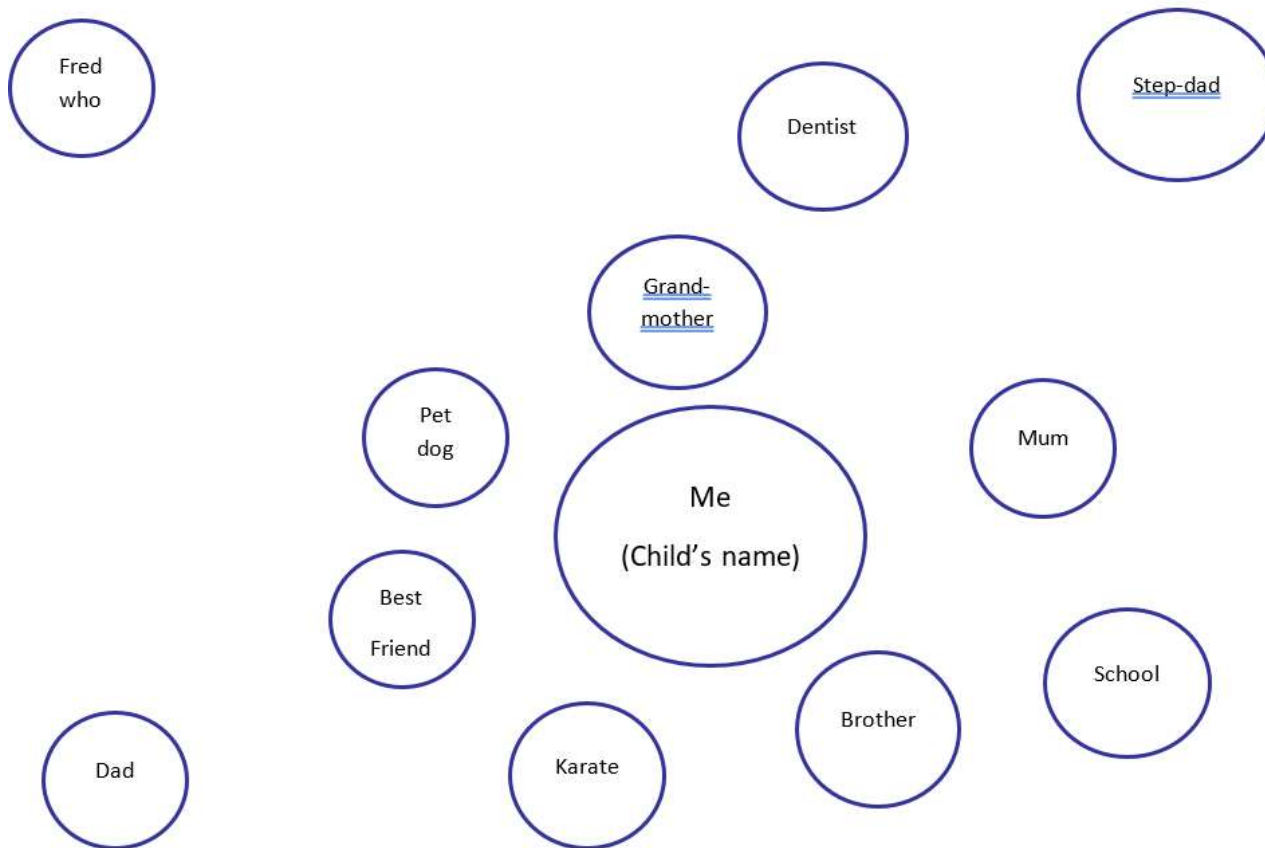

In this example the child's name goes in the middle and they decide where to place the people in their lives.

We capture how the child feels about the members of their family, their school and peer experiences and their pet

EXAMPLE 2

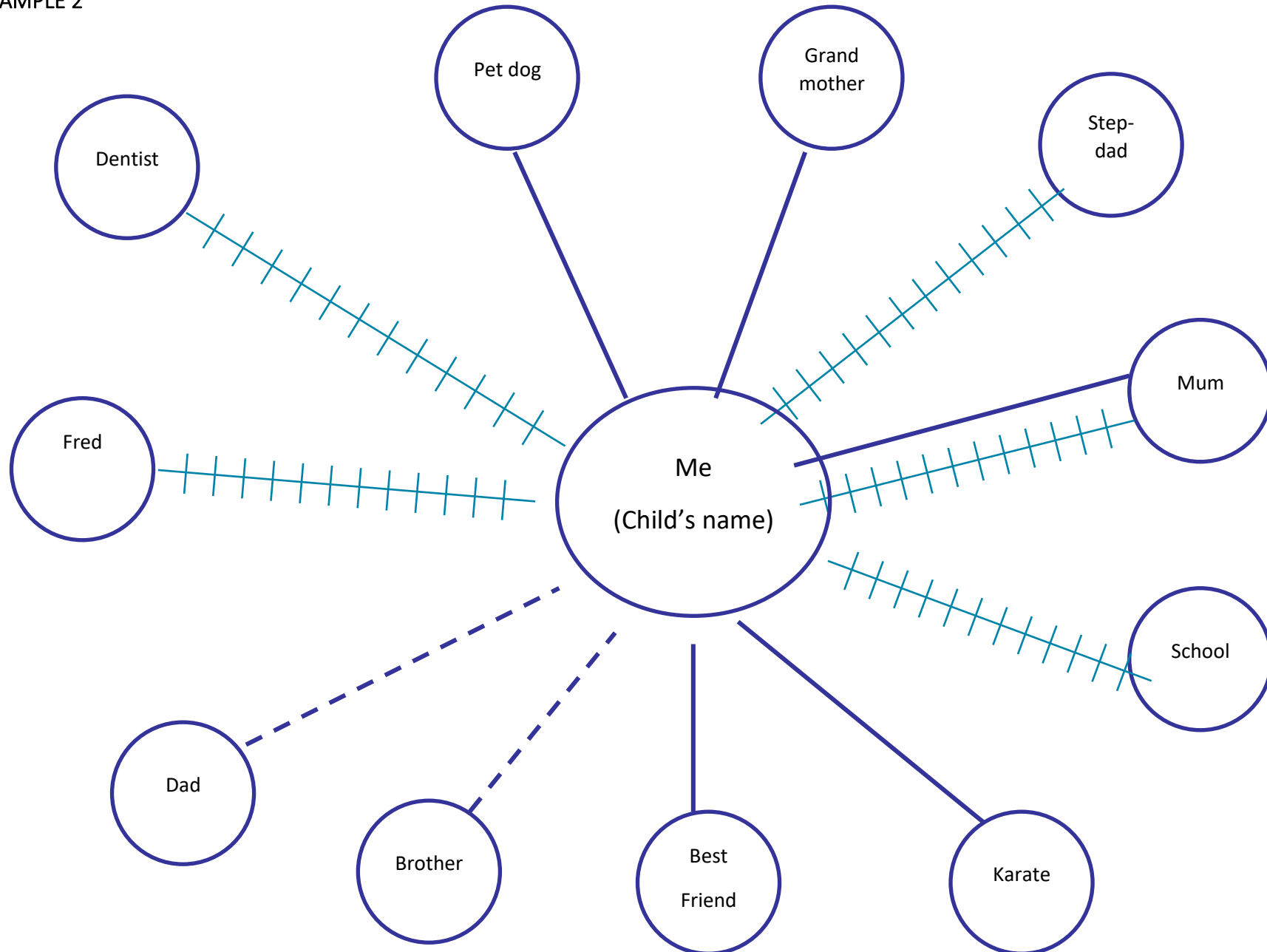

In this example we have used different types of lines to describe relationships. Two types of lines have been used for the relationship with mum, to show it can be good and stressful

Example 3

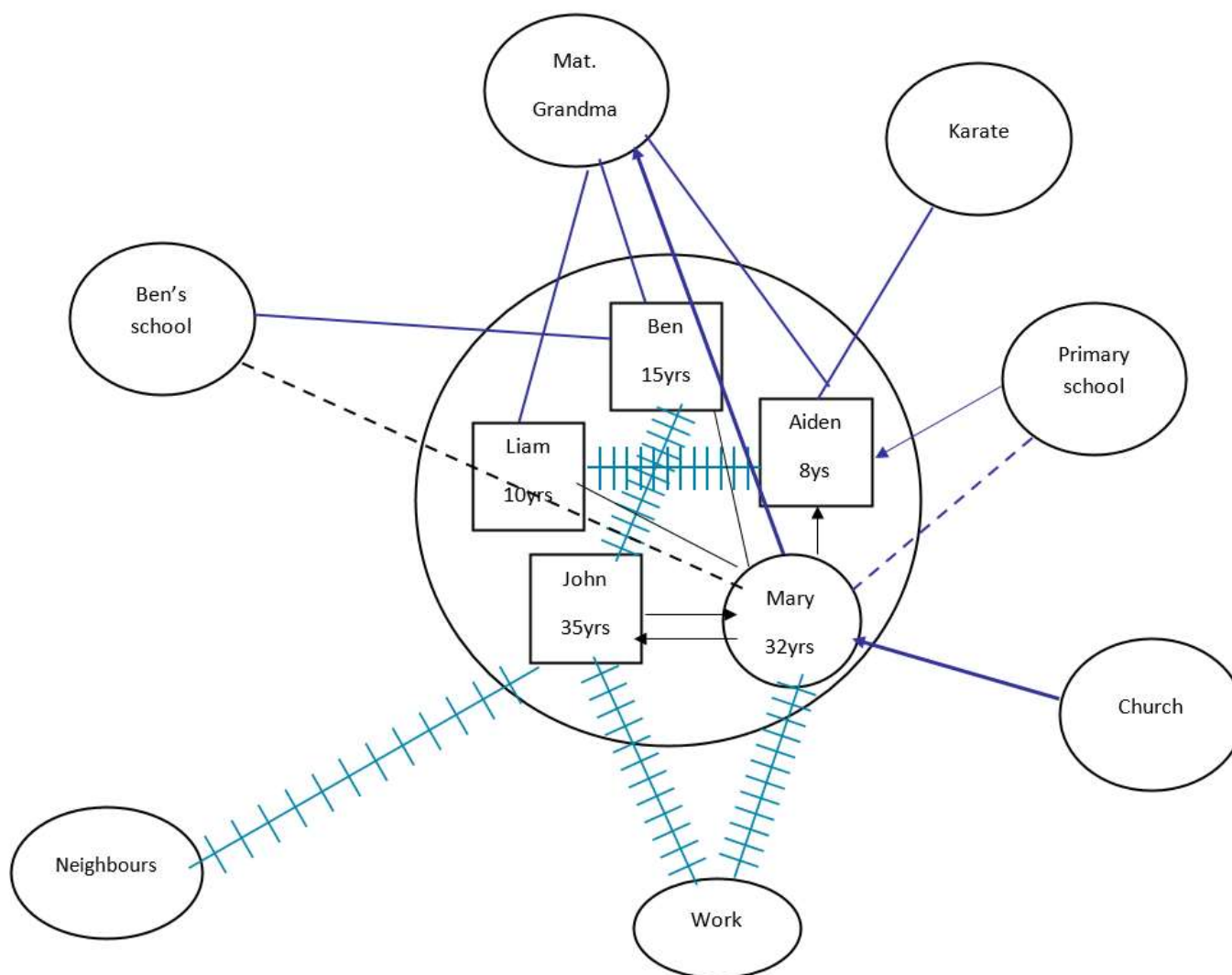

In this example of a family eco map, we can see that Ben has a stressful relationship with his Dad and that Aiden and Liam have stressful relationships. The parent's relationship is equal, mum has good relationships with Liam and Ben, but Aiden is hard work.

Dad has a stressful relationship with his neighbours, whilst mum finds the church supportive. Mum's links with the boy's school is tenuous, whilst Ben enjoys school, and Aiden's school find him hard work. Aiden enjoys Karate and all the boys enjoy relationship with Grandma, although mum finds it requires energy from her.